

GAME PLAYING

Adversarial search

- One of the reasons we use search in AI is to help agents figure out what to do.
- Considering how sequences of actions can be put together allows the agent to plan.
- (We will come back to this topic again in a few lectures' time).
- Using the techniques we have covered so far, we can have a single agent figure out what to do when:
 - It knows exactly how the world is;
 - Each action only has one outcome; and
 - The world only changes when the agent makes it change.

cis716-spring2004-parsons-lect09

2

- In other words we can plan when the world is:
 - Accessible;
 - Deterministic; and
 - Static
- Obviously these are unrealistic simplifications.
- Here we will consider how to handle one kind of dynamism:
 - Other agents messing with the world.
- (Later lectures will look at other kinds of complication.)

- Consider a set up where we have two agents moving in the grid world:

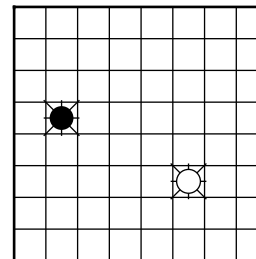

© 1998 Morgan Kaufman Publishers

- We assume that agents take it in turn to move.

cis716-spring2004-parsons-lect09

3

cis716-spring2004-parsons-lect09

4

- One typical kind of scenario which fits this profile is a two-person game.
- Consider that White wants to be in the same cell as Black.
- Black wants to avoid this.
- (These could be moves in a chess endgame.)
- What each agent wants is a move that guarantees success whatever the other does.
- Usually all they can find is a move that improves things from their point of view.

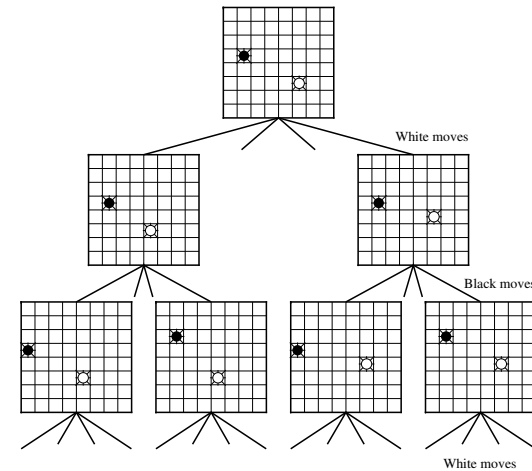

Computers and Games

- This example is a *two person, perfect information, zero sum* game.
- Perfect information:
 - Both players know exactly what the state of the game is.
- Zero sum:
 - What is good for one player is bad for the other.
- This is also true of chess, draughts, go, othello, connect 4, ...

- These games are relatively easy to study at an introductory level.
- They have been studied just about as long as AI has been a subject.
- Some games are easily “solved”:
 - Tic-Tac-Toe
- Others have held out until recently.
 - Checkers
 - Chess
- Yet others are far from being mastered by computers.
 - Go
- Chance provides another complicating element.

- For many of these games
 - State space
 - Iconic representations seem natural.
- Moves are represented by state space operators.
- Search trees can be built much as before.
- However, we use different techniques to choose the optimal moves.

Minimax procedure

- Typically we name the two players MAX and MIN.
- MAX moves first, and we want to find the best move for MAX.
- Since MAX moves first, even numbered layers are the ones where MAX gets to choose what move to make.
- The first node is on the zeroth layer.
- We call these “MAX nodes”.
- “Min nodes” are defined similarly.
- A *ply of ply-depth k* are the nodes at depth $2k$ and $2k + 1$.
- We usually estimate, in ply, the depth of the “lookahead” performed by both agents.

- We can't search the whole tree:
 - Chess: 10^{40} nodes
 - 10^{22} centuries to build search tree.
- So just search to a limited horizon (like depth-bounded).
- Then evaluate (using some heuristic) the leaf nodes.
- Then extract the best move at the top level.
- How do we do this (and how do we take into account the fact that MIN is also trying to win)?
- We use the minimax procedure.

- Assume our heuristic gives nodes high positive values if they are good for MAX
- And low values if they are good for MIN.
- Now, look at the leaf nodes and consider which ones MAX wants:
 - Ones with high values.
- MAX could choose these nodes *if* it was his turn to play.
- So, the value of the MAX-node parent of a set of nodes is the max of all the child values.

- Similarly, when MIN plays she wants the node with the lowest value.
- So the MIN-node parent of a set of nodes gets the min of all their values.
- We back up values until we get to the children of the start node, and MAX can use this to decide which node to choose.
- There is an assumption (another!) which is that the evaluation function works as a better guide on nodes down the tree than on the direct successors of the start node.
- This should be the case (modulo horizon effects).
- Let's look at a concrete example—Tic-Tac-Toe.

- Let MAX play crosses and go first.
- Breadth-first search to depth 2.
- evaluation function $e(p)$:

$$e(p) = \begin{cases} \infty & \text{if } p \text{ is a win for MAX} \\ -\infty & \text{if } p \text{ is a win for MIN} \\ val & \text{otherwise} \end{cases}$$

where

$$val = (\text{possible winning rows columns diagonals for MAX}) - (\text{possible winning rows columns diagonals for MIN})$$

- So,



© 1998 Morgan Kaufman Publishers

- Scores:

$$6 - 4 = 2$$

- We also use symmetry to avoid having to generate loads of successor states, so

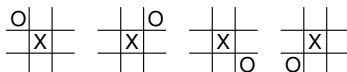

© 1998 Morgan Kaufman Publishers

- are all equivalent.
- So, run the depth 2 search, evaluate, and back up values

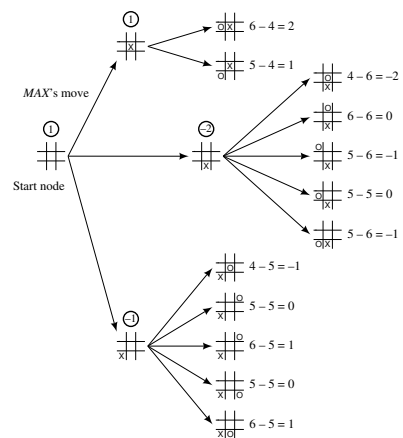

© 1998 Morgan Kaufman Publishers

Alpha-Beta search

- Minimax works very neatly, but it is inefficient.
- The inefficiency comes from the fact that we:
 - Build the tree,
 - THEN back up the values
- If we combine the two we get massive savings in computation.
- How do we manage this?

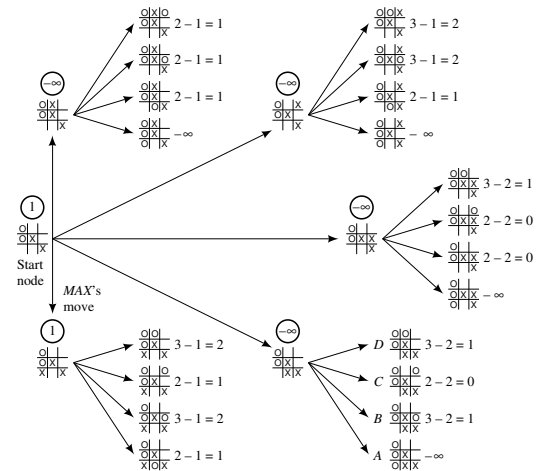

- Well, when we get to node A, we don't have to expand any further.
- So we save the evaluation of B, C and D.
- We also don't have to search any of the nodes below these nodes.
- This does nothing to stop MAX finding the best move.
- It also works when we don't have a winning move for MIN.
- Consider the following (earlier) stage of Tic-Tac-Toe.

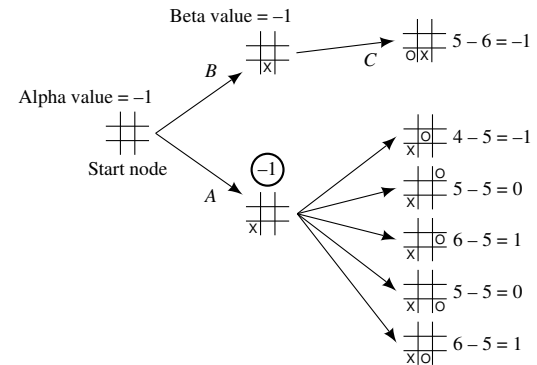

- Consider we have generated A and its successors, but not B.

- Node A has backed-up value -1.
- Thus the start node cannot have a lower value than -1.
- This is the *alpha* value.
- Now let's go on to B and C.
- Since C has value -1, B cannot have a greater value than -1.
- This is the *beta* value.
- In this case, because B cannot ever be better than A, we can stop the expansion of B's children.

- In general:
 - Alpha values of MAX nodes can never decrease.
 - Beta values of MIN nodes can never increase.
- Thus we can stop searching below:
 - Any MIN node with a beta value less than or equal to the alpha value of one of its MAX ancestors.
The backed up value of this MIN can be set to its beta value.
 - Any MAX node with an alpha value greater than or equal to any of its MIN node ancestors.
The backed up value of this MAX node can be set to its alpha value.

- We compute the values as:
 - Alpha: current largest final backed-up value of successors.
 - Beta: current smallest final backed-up value of successors.
- We keep searching until we meet the “stop search” *cut-off* rules, or we have backed-up values for all the successors of the start node.
- Doing this always gives the same best move as full minimax.
- However, often (usually) this alpha-beta approach involves less searching.

Horizon effects

- How do we know when to stop searching?
- What looks like a very good position for MAX might be a very bad position just over the horizon.
- Stop at *quiescent* nodes (value is the same as it would be if you looked ahead a couple of moves).
- Can be exploited by opponents; pushing moves back behind the horizon.
- A similar problem occurs because we assume that players always make their best move:
 - “Bad” moves can mislead a minimax-style player.

Games of chance

- How do we handle dice games?
- A neat trick is to model this as a another player DICE.
- We back up values in the usual way, maximising for MAX and minimising for MIN.
- For DICE moves, we back up the expected (weighted average) of the moves.
- For a single die, the weight is $1/6$.
- For more complex situations we use whatever probability distribution is indicated.

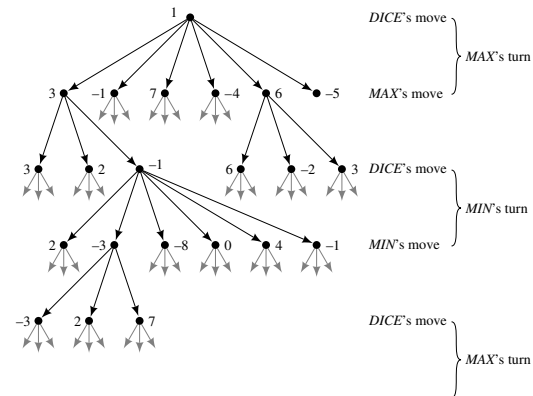

Summary

- We have looked at game playing as adversarial state-space search.
- Minimax search is the basic technique for finding the best move.
- Alpha/beta search gives greater efficiency.
- Games of chance can be handled by adding in the random player DICE.